

No part of this product may be reproduced in any form or by any electronic or mechanical means, including information storage and retrieval systems, without written permission from the IB.

Additionally, the license tied with this product prohibits commercial use of any selected files or extracts from this product. Use by third parties, including but not limited to publishers, private teachers, tutoring or study services, preparatory schools, vendors operating curriculum mapping services or teacher resource digital platforms and app developers, is not permitted and is subject to the IB's prior written consent via a license. More information on how to request a license can be obtained from <http://www.ibo.org/contact-the-ib/media-inquiries/for-publishers/guidance-for-third-party-publishers-and-providers/how-to-apply-for-a-license>.

Aucune partie de ce produit ne peut être reproduite sous quelque forme ni par quelque moyen que ce soit, électronique ou mécanique, y compris des systèmes de stockage et de récupération d'informations, sans l'autorisation écrite de l'IB.

De plus, la licence associée à ce produit interdit toute utilisation commerciale de tout fichier ou extrait sélectionné dans ce produit. L'utilisation par des tiers, y compris, sans toutefois s'y limiter, des éditeurs, des professeurs particuliers, des services de tutorat ou d'aide aux études, des établissements de préparation à l'enseignement supérieur, des fournisseurs de services de planification des programmes d'études, des gestionnaires de plateformes pédagogiques en ligne, et des développeurs d'applications, n'est pas autorisée et est soumise au consentement écrit préalable de l'IB par l'intermédiaire d'une licence. Pour plus d'informations sur la procédure à suivre pour demander une licence, rendez-vous à l'adresse <http://www.ibo.org/fr/contact-the-ib/media-inquiries/for-publishers/guidance-for-third-party-publishers-and-providers/how-to-apply-for-a-license>.

No se podrá reproducir ninguna parte de este producto de ninguna forma ni por ningún medio electrónico o mecánico, incluidos los sistemas de almacenamiento y recuperación de información, sin que medie la autorización escrita del IB.

Además, la licencia vinculada a este producto prohíbe el uso con fines comerciales de todo archivo o fragmento seleccionado de este producto. El uso por parte de terceros —lo que incluye, a título enunciativo, editoriales, profesores particulares, servicios de apoyo académico o ayuda para el estudio, colegios preparatorios, desarrolladores de aplicaciones y entidades que presten servicios de planificación curricular u ofrezcan recursos para docentes mediante plataformas digitales— no está permitido y estará sujeto al otorgamiento previo de una licencia escrita por parte del IB. En este enlace encontrará más información sobre cómo solicitar una licencia: <http://www.ibo.org/es/contact-the-ib/media-inquiries/for-publishers/guidance-for-third-party-publishers-and-providers/how-to-apply-for-a-license>.

Mathematical studies
Standard level
Paper 1

Monday 13 May 2019 (afternoon)

Candidate session number

1 hour 30 minutes

| | | | | | | | | | |
|--|--|--|--|--|--|--|--|--|--|
| | | | | | | | | | |
|--|--|--|--|--|--|--|--|--|--|

Instructions to candidates

- Write your session number in the boxes above.
- Do not open this examination paper until instructed to do so.
- A graphic display calculator is required for this paper.
- A clean copy of the **mathematical studies SL formula booklet** is required for this paper.
- Answer all questions.
- Answers must be written within the answer boxes provided.
- Unless otherwise stated in the question, all numerical answers should be given exactly or correct to three significant figures.
- The maximum mark for this examination paper is **[90 marks]**.



Please **do not** write on this page.

Answers written on this page
will not be marked.



Maximum marks will be given for correct answers. Where an answer is incorrect, some marks may be given for a correct method, provided this is shown by written working. Answers must be written within the answer boxes provided. Solutions found from a graphic display calculator should be supported by suitable working, for example, if graphs are used to find a solution, you should sketch these as part of your answer.

- 1. A calculator fits into a cuboid case with height 29 mm, width 98 mm and length 186 mm.
 - (a) Find the volume, in mm^3 , of this calculator case. Give your answer to two significant figures. [2]
 - (b) Write down your answer to part (a) in the form $a \times 10^k$ where $1 \leq a < 10$ and $k \in \mathbb{Z}$. [2]
 - (c) Find the volume, in cm^3 , of this calculator case. [2]

Working:

Answers:

- (a)
- (b)
- (c)



2. The fastest recorded speeds of eight animals are shown in the following table.

| Animal | Speed (km h ⁻¹) |
|---------------|-----------------------------|
| Golden eagle | 300 |
| Swordfish | 97 |
| Hare | 80 |
| Lion | 80 |
| Horse | 71 |
| Zebra | 64 |
| Komodo dragon | 21 |
| Tiger beetle | 6 |

- (a) State whether **speed** is a continuous or discrete variable. [1]
- (b) Write down the median speed for these animals. [1]
- (c) Write down the range of the animal speeds. [1]
- (d) For these eight animals
 - (i) find the mean speed;
 - (ii) write down the standard deviation. [3]

Working:

Answers:

- (a)
- (b)
- (c)
- (d) (i)
- (ii)



3. Consider the following propositions.

p : I am tired
 q : I am happy

(a) Write down in words $p \wedge q$. [1]

(b) Write down the inverse of $p \Rightarrow q$ in symbolic form. [1]

(c) Write down, in symbolic form, the compound statement:
If I am not happy then I am tired. [2]

(d) Complete the following truth table. [2]

| p | q | I am not happy | $q \Rightarrow p$ |
|-----|-----|----------------|-------------------|
| T | T | | |
| T | F | | |
| F | T | | |
| F | F | | |

Working:

Answers:

- (a)
-
-
- (b)
- (c)



4. Line L_1 passes through the points $A(-3, 0.5)$ and $B(9, -3.5)$.

(a) Find the gradient of L_1 . [2]

Line L_2 passes through the point $C(3, 1)$ and is parallel to L_1 .

(b) Determine the equation of L_2 . Give your answer in the form $ax + by + d = 0$, where a , b and d are integers. [2]

(c) Find the coordinates of the x -intercept of L_2 . [2]

Working:

Answers:

(a)

(b)

(c)



5. A florist sells bouquets of roses. The florist recorded, in **Table 1**, the number of roses in each bouquet sold to customers.

Table 1

| | | | | | | | | | | | |
|--|---|---|---|---|---|---|----|---|----|----|----|
| Number of roses in a bouquet (<i>n</i>) | 2 | 3 | 4 | 5 | 6 | 7 | 8 | 9 | 10 | 11 | 12 |
| Number of customers (<i>f</i>) | 9 | 2 | 4 | 5 | 7 | 3 | 10 | 2 | 3 | 1 | 4 |

The roses can be arranged into bouquets of size small, medium or large. The data from **Table 1** has been organized into a cumulative frequency table, **Table 2**.

Table 2

| Bouquet size | Number of roses (<i>n</i>) | Frequency (<i>f</i>) | Cumulative frequency |
|---------------------|-----------------------------------|-----------------------------|-----------------------------|
| small | $2 \leq n \leq 4$ | 15 | |
| medium | $5 \leq n \leq 8$ | 25 | |
| large | $9 \leq n \leq 12$ | | |

- (a) Complete the cumulative frequency table. [2]
- (b) Write down the probability that a bouquet of roses sold is **not** small. [2]

A customer buys a large bouquet.

- (c) Find the probability that there are 12 roses in this bouquet. [2]

Working:

Answers:

(b)

(c)



6. Money boxes are coin containers used by children and come in a variety of shapes. The money box shown is in the shape of a cylinder. It has a radius of 4.43 cm and a height of 12.2 cm.

diagram not to scale



- (a) Find the volume of the money box.

[3]

A second money box is in the shape of a sphere and has the same volume as the cylindrical money box.

diagram not to scale



- (b) Find the diameter of the second money box.

[3]

(This question continues on the following page)



(Question 6 continued)

Working:

Answers:

(a)

(b)



20EP09

Turn over

7. (a) Place the numbers 2π , -5 , 3^{-1} and $2^{\frac{3}{2}}$ in the correct position on the Venn diagram. [4]

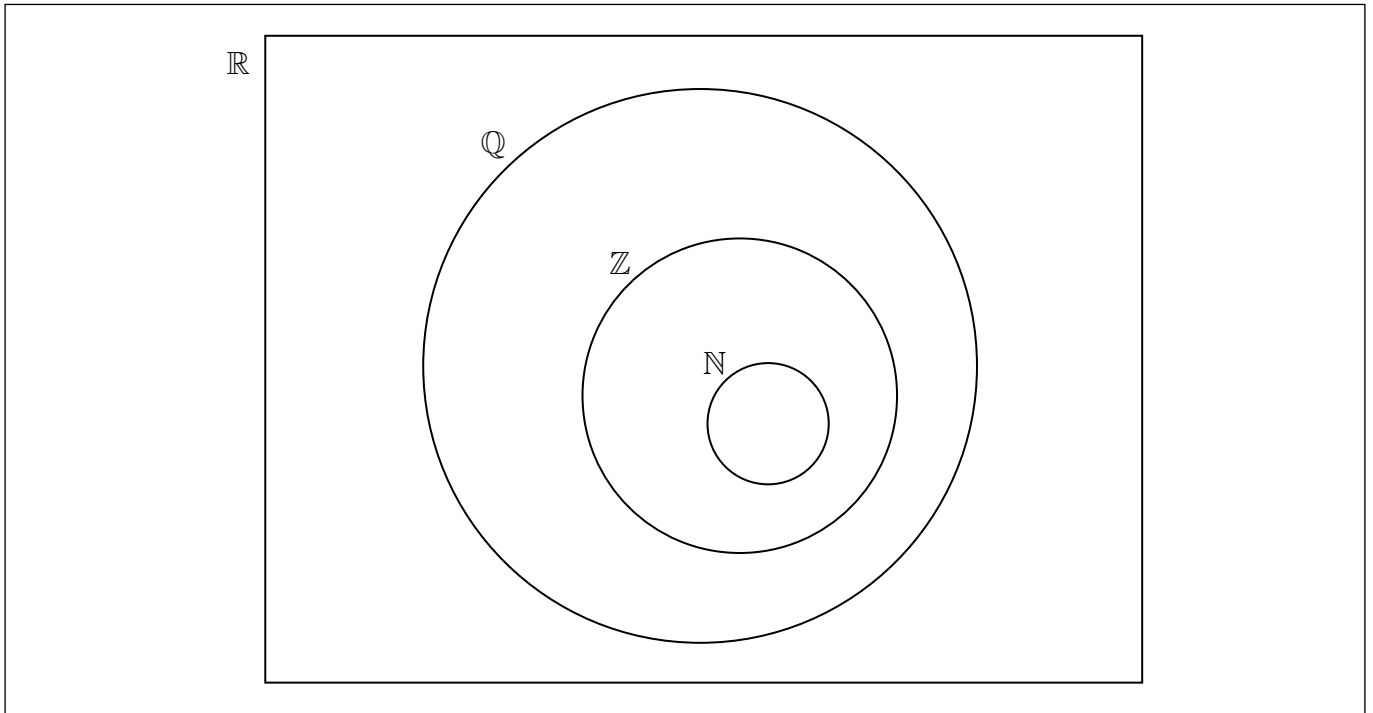

- (b) In the table indicate which **two** of the given statements are true by placing a tick (✓) in the right hand column. [2]

| Statement | True |
|-----------------|------|
| $Z \subset Q$ | |
| $N \subset Q'$ | |
| $N \cap Z = N$ | |
| $Q \cup R = Z'$ | |

Working:



8. A buoy is floating in the sea and can be seen from the top of a vertical cliff. A boat is travelling from the base of the cliff directly towards the buoy.

The top of the cliff is 142 m above sea level. Currently the boat is 100 metres from the buoy and the angle of depression from the top of the cliff to the boat is 64° .

diagram not to scale

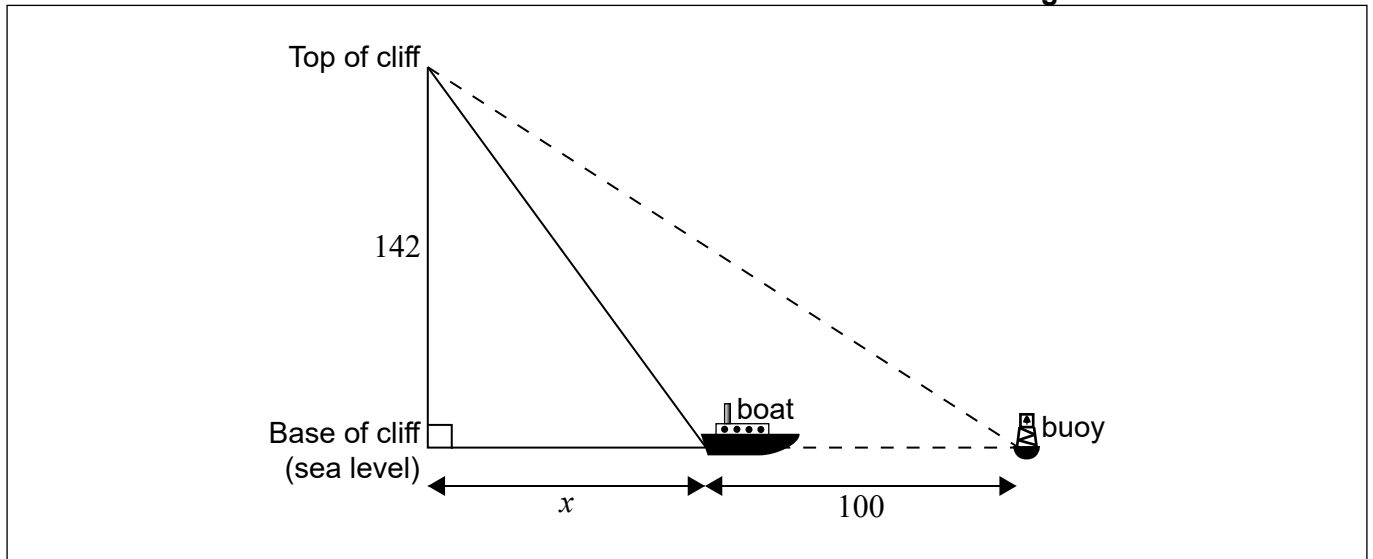

- (a) Draw and label the angle of depression on the diagram. [1]
- (b) Find x , the horizontal distance currently between the base of the cliff and the boat. [2]
- (c) Find the distance from the **top of the cliff** to the buoy. [3]

Working:

Answers:

(b)

(c)



9. Juan pays 8.75 euros (EUR) for a single movie ticket. The total amount Juan pays for movie tickets in a year can be modelled by

$$y = 8.75x$$

where x represents the number of tickets purchased per year and y represents the total amount, in EUR, paid per year.

Last year Juan spent less than 60 EUR.

- (a) Determine the maximum number of movie tickets Juan purchased last year. [3]

Maureen buys an annual movie ticket discount card for 50 EUR and then pays 2.50 EUR for each movie ticket.

- (b) Write down an equation in terms of x and y , using Maureen's information. [1]

During this year, Juan and Maureen will **each** buy the same number of tickets and will each pay the same total amount of money.

- (c) Find the number of tickets Juan will buy this year. [2]

Working:

Answers:

- (a)
- (b)
- (c)



10. Three airport runways intersect to form a triangle, ABC. The length of AB is 3.1 km, AC is 2.6 km, and BC is 2.4 km.

diagram not to scale

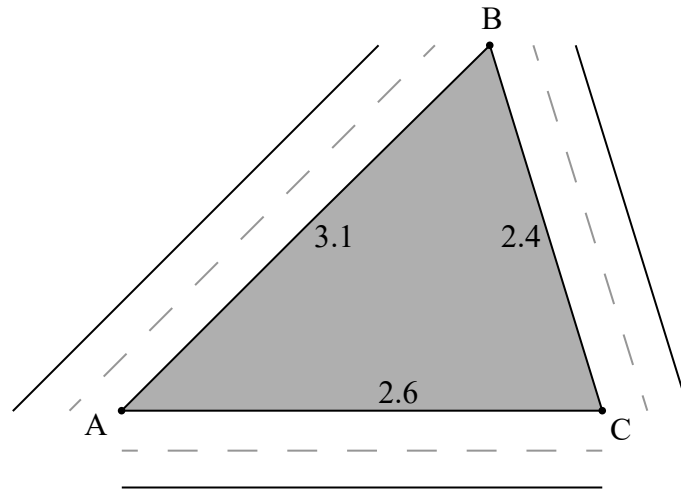

A company is hired to cut the grass that grows in triangle ABC, but they need to know the area.

- (a) Find the size, in degrees, of angle \hat{BAC} . [3]
- (b) Find the area, in km^2 , of triangle ABC. [3]

Working:

Answers:

(a)

(b)



11. Consider the following graphs of normal distributions.

Graph A

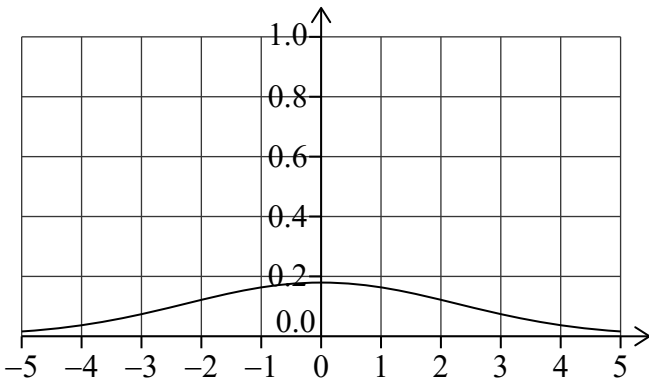

Graph B

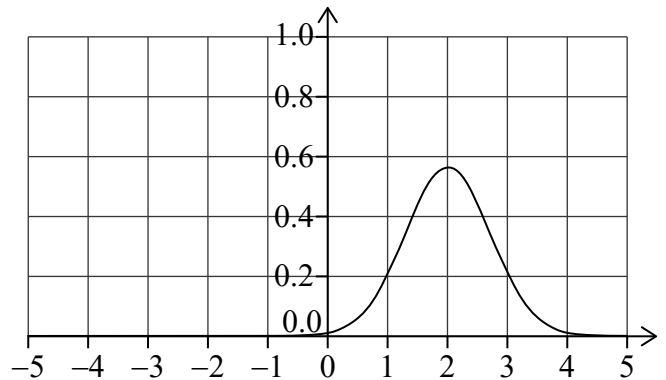

Graph C

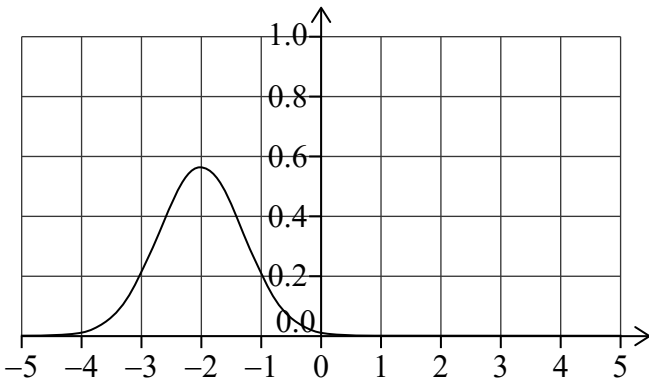

Graph D

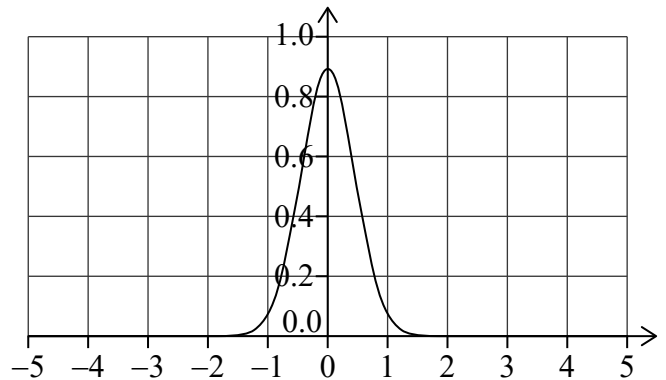

- (a) In the following table, write down the letter of the corresponding graph next to the given mean and standard deviation. [2]

| Mean and standard deviation | Graph |
|---------------------------------------|-------|
| Mean = -2; standard deviation = 0.707 | |
| Mean = 0; standard deviation = 0.447 | |

At an airport, the weights of suitcases (in kg) were measured. The weights are normally distributed with a mean of 20 kg and standard deviation of 3.5 kg.

- (b) Find the probability that a suitcase weighs less than 15 kg. [2]

Any suitcase that weighs more than k kg is identified as excess baggage. 19.6% of the suitcases at this airport are identified as excess baggage.

- (c) Find the value of k . [2]

(This question continues on the following page)



(Question 11 continued)

Working:

Answers:

(b)

(c)



12. The diagram shows a circular horizontal board divided into six equal sectors. The sectors are labelled white (W), yellow (Y) and blue (B).

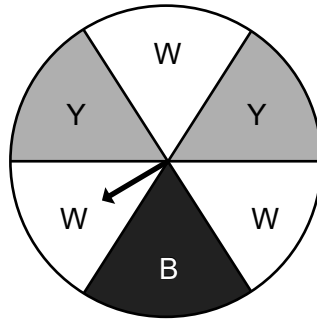

A pointer is pinned to the centre of the board. The pointer is to be spun and when it stops the colour of the sector on which the pointer stops is recorded. The pointer is equally likely to stop on any of the six sectors.

Eva will spin the pointer twice. The following tree diagram shows all the possible outcomes.

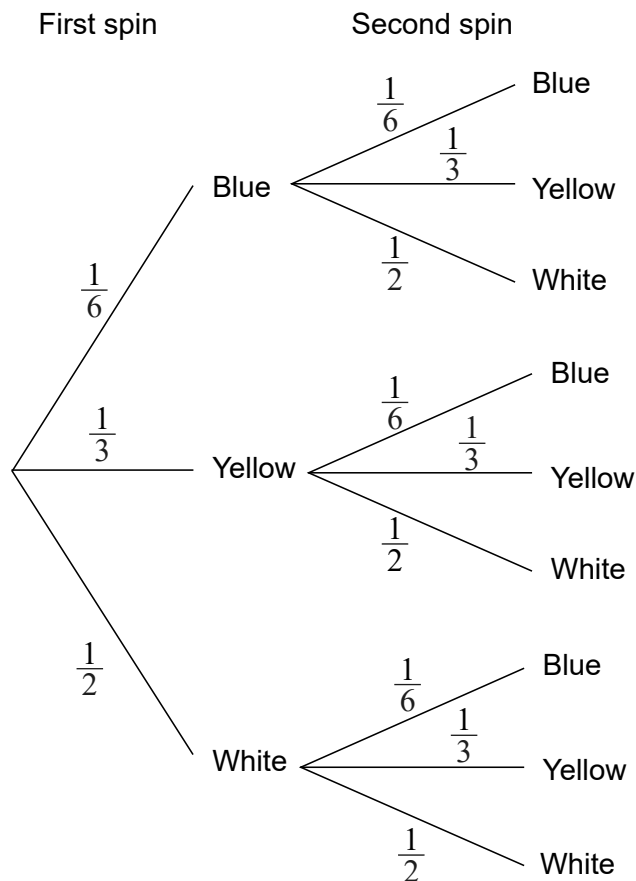

- (a) Find the probability that both spins are yellow. [2]
- (b) Find the probability that at least one of the spins is yellow. [3]
- (c) Write down the probability that the second spin is yellow, given that the first spin is blue. [1]

(This question continues on the following page)



(Question 12 continued)

Working:

Answers:

- (a)
- (b)
- (c)



13. The graph of a quadratic function is shown.

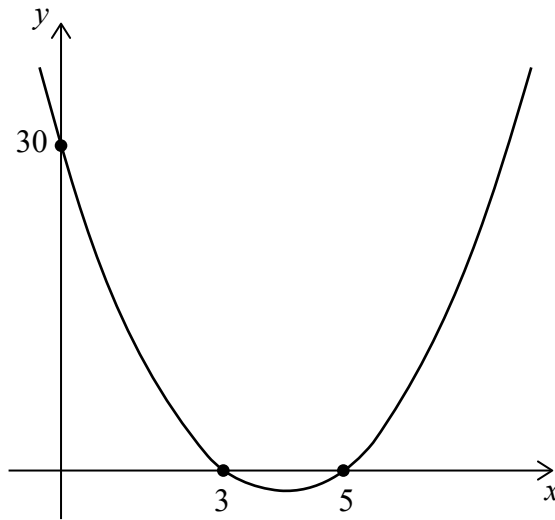

- (a) Find the equation of the quadratic function in the form $y = ax^2 + bx + 30$. [4]
- (b) Write down the equation of the axis of symmetry. [2]

Working:

Answers:

(a)

(b)



14. Devra invested k US dollars (USD) in an account that pays a nominal annual interest rate of 3.1%, **compounded monthly**. After 6 years she has 1100 USD in the account.

(a) Calculate the value of k . **Give your answer to 2 decimal places.** [3]

Devra then bought a computer that cost 1100 USD and sold it 4 years later for 350 USD.

(b) Find the rate at which the computer depreciated per year. [3]

Working:

Answers:

(a)

(b)



15. A cylinder with radius r and height h is shown in the following diagram.

diagram not to scale

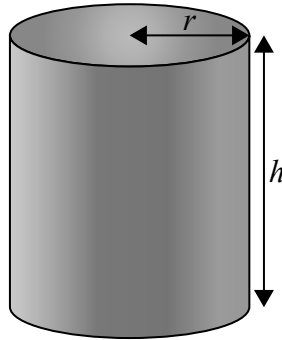

The sum of r and h for this cylinder is 12 cm.

- (a) Write down an equation for the area, A , of the **curved** surface in terms of r . [2]
- (b) Find $\frac{dA}{dr}$. [2]
- (c) Find the value of r when the area of the curved surface is maximized. [2]

Working:

Answers:

- (a)
- (b)
- (c)

